

FUEGO

®



Fuego Modular
6 Unit Modular
Outdoor Kitchen

Big and bold with enough mass appeal to wow a crowd, the award-winning Fuego Modular delivers a fully customized outdoor kitchen with room to grow. It can be configured any way you want—freestanding or mounted—with separate stainless steel modules for grilling, warming, storing, cooling, washing, and gawking.

Specifications

A. Utility Unit (model - FM20AUU)

Color

Commercial Grade Stainless Steel exterior, black powder coated steel interior.

Features

Housing Unit
 (2) Storage Cabinets (Model# FM20AUS)
 Countertop Template
 Modular Accessory System
 Leveling Legs
 Junction Box Cutout

Optional Features/Dealer Options (sold separately)

24" Double Drawer Refrigeration Unit

Overlay kits are available for select under counter refrigeration models.

B. Storage Unit (model - FM20ASU)

Color

Commercial Grade Stainless Steel exterior, black powder coated steel interior.

Features

19" Storage Module
 Large Drawer (propane or interchangeable drawer storage)
 3/4" Teak Countertop

C. Grill Unit with Gas Drawer (model - FM20AGU)

Color

Commercial Grade Stainless Steel exterior, black powder coated steel interior.

Features

Patented Quick Change Drawer System
 Lower Sliding Storage Drawer
 4" Cooking Lid
 Built in Residue Tray
 Battery Ignition

SS Gas Burner

18,500 btu/hr

Burner Options (sold as accessory)

Charcoal Interchangeable Drawer
 Infrared Interchangeable Drawer

Grilling Area

468 sq. in

Grill Grates

Cast Iron, enamel coated

Controls

Infinite Control knobs

D. Grill Unit with Infrared Drawer (model - FM20AIU)

Color

Commercial Grade Stainless Steel exterior, black powder coated steel interior.

Features

Patented Quick Change Drawer System
 Lower Sliding Storage Drawer
 4" Cooking Lid
 Built in Residue Tray
 Battery Ignition

Infrared Gas Burner Gas Burner

15,000 btu/hr

Burner Options (sold as accessory)

Charcoal Interchangeable Drawer
 Gas Interchangeable Drawer

Grilling Area

468 sq. in

Grill Grates

Cast Iron, enamel coated

Controls

Infinite Control knobs

E. Cook Unit (model - FM20ACU)

Color

Commercial Grade Stainless Steel exterior, black powder coated steel interior.

Features

Dual sealed gas burners
 Lower Sliding Storage Drawer
 4" Cooking Lid
 Built in Residue Tray
 Battery Ignition

Gas Burner

2 @ 12,000 btu/hr

Controls

Infinite Control knobs

F. Warm Unit (model - FM20AWU)

Color

Commercial Grade Stainless Steel exterior, black powder coated steel interior.

Features

Upper Storage Drawer
 Lower Sterno fueled warming drawer (Sterno not included)
 (2) chafing pans with lids
 3/4" Slate countertop

G. Light Unit (model - FM20ALU)

Color

Aluminum

Features

Aluminum light frame
 (3) Directional Halogen Lights (MR16)
 110 volts

H. Mounting Frame Unit

Color

Aluminum

Free-standing Island configuration (model - FM20AMU)

Features

(2) 8'4" L Mounting Beams
 (3) 39 3/4" H Counter Legs
 Dining Counter Template

I. End Panels (FM20AEP/FM20BEP)

Set A (FM20AEP) end panel units without light
 Set B (FM20BEP) end panel units with light (either left or right side)

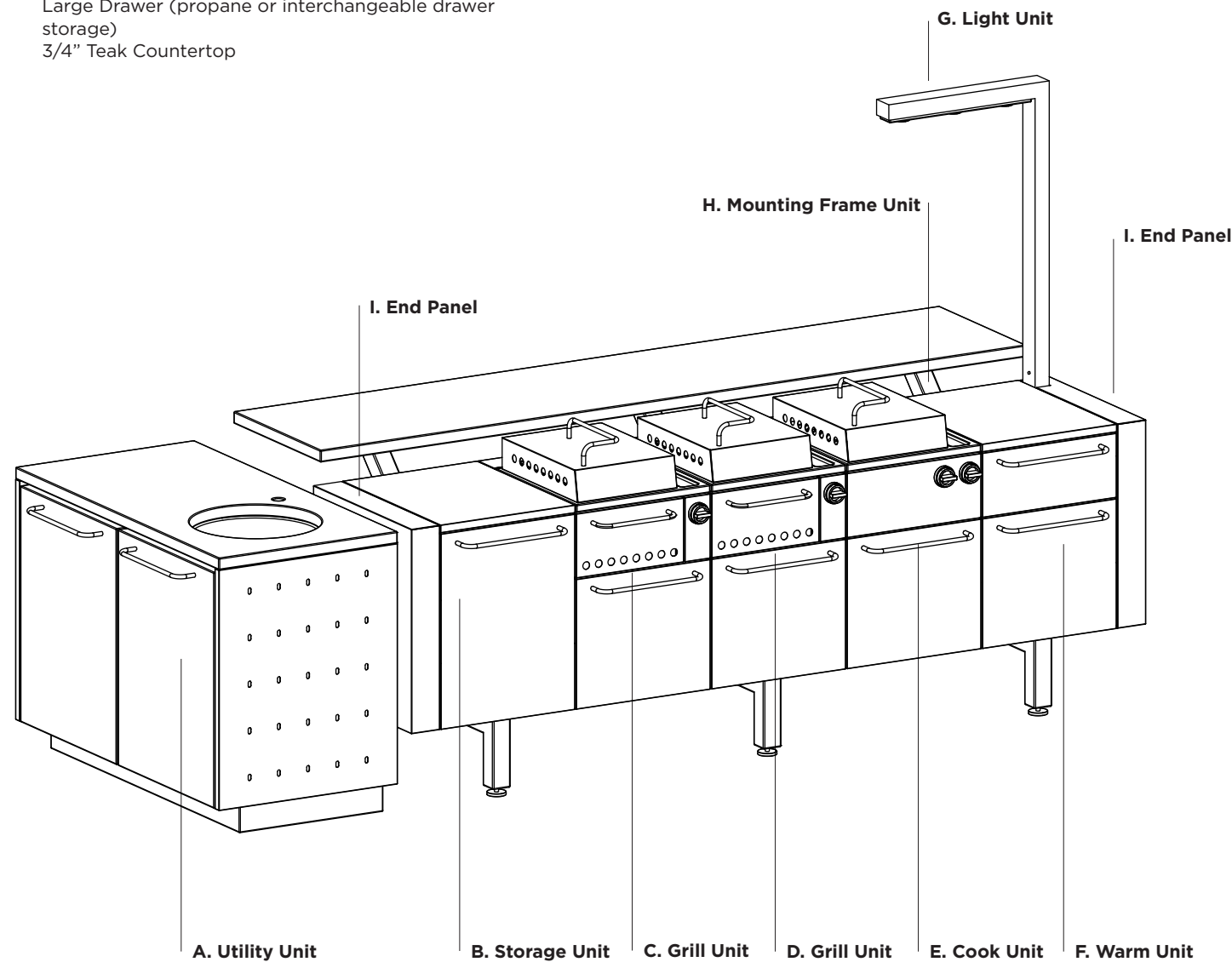

Utility Unit Diagram

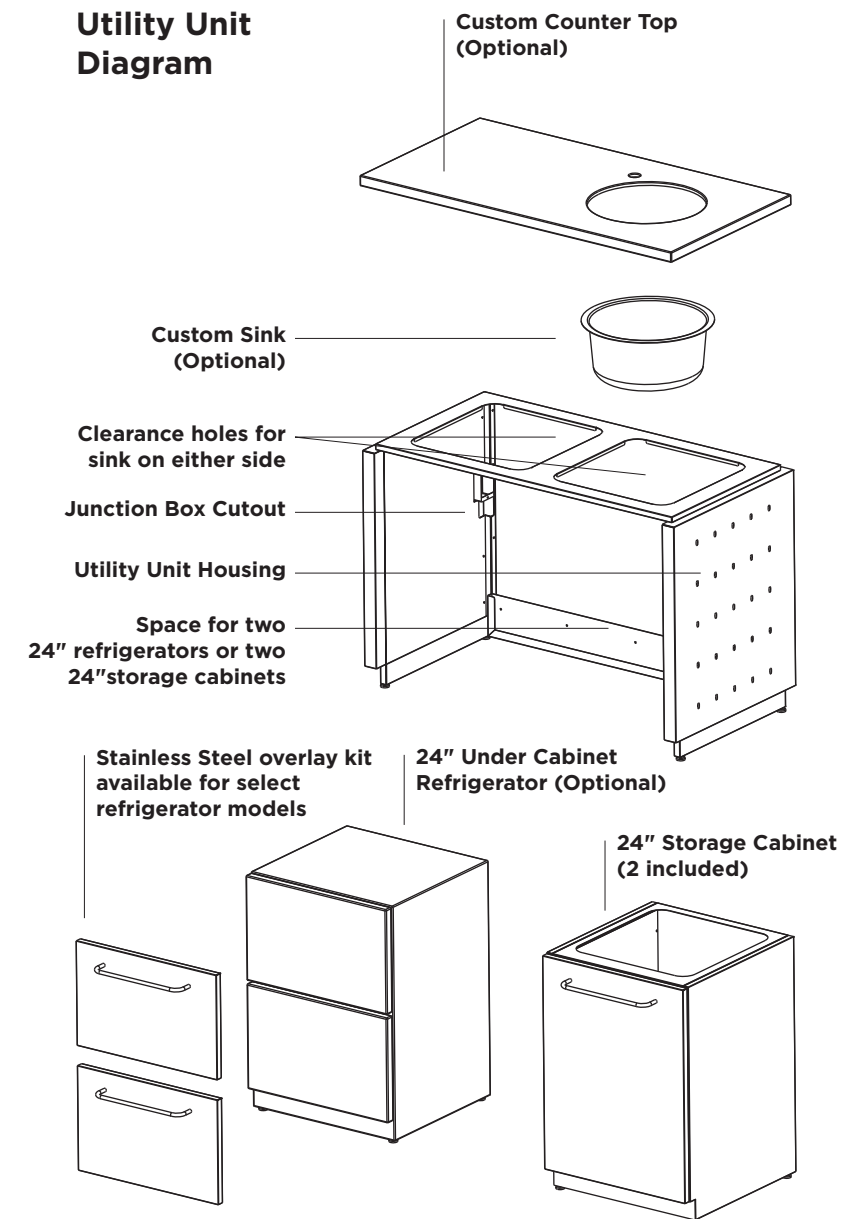

Assembly required. All necessary hardware included.

Gas Requirements

Natural

All modules come standard with NG connections.

Propane

A separate LP kit is available.

Accessories (sold separately)

- FA20ACD Charcoal Drawer Option
- FA20AID Infrared Drawer Option
- FA20AGD Gas Drawer Option
- FA00ATH Paper Towel Holder
- FA00ACT Ceramic Tray Set
- FA00ASP Spice Accessory Jars (8)
- FA00ABB Beverage Bucket
- FA00AGP Griddle/Flat Plate
- FA00ALL 7" Large Cooking Lid
- FA20ALP LP Conversion Kit

Warranty

All modules are covered by a one (1) year comprehensive parts and labor warranty. In addition, a five (5) year limited parts warranty covers specific parts by model.

A limited lifetime warranty covers all stainless steel components against manufacturer related defects. This excludes discoloration or surface corrosion resulting from improper use and care. Please refer to user manual for proper care and maintenance.

Specifications are subject to change without notice. Please call 888.88.FUEGO or check our website at www.fuegoliving.com for potential specification updates.

Fuego North America Roundhouse One, 1500 Sansome Street #100, San Francisco, CA, 94111

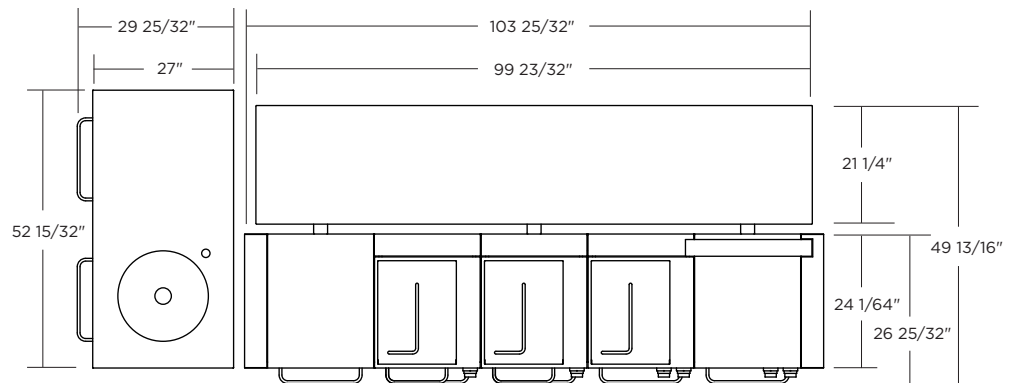

Top

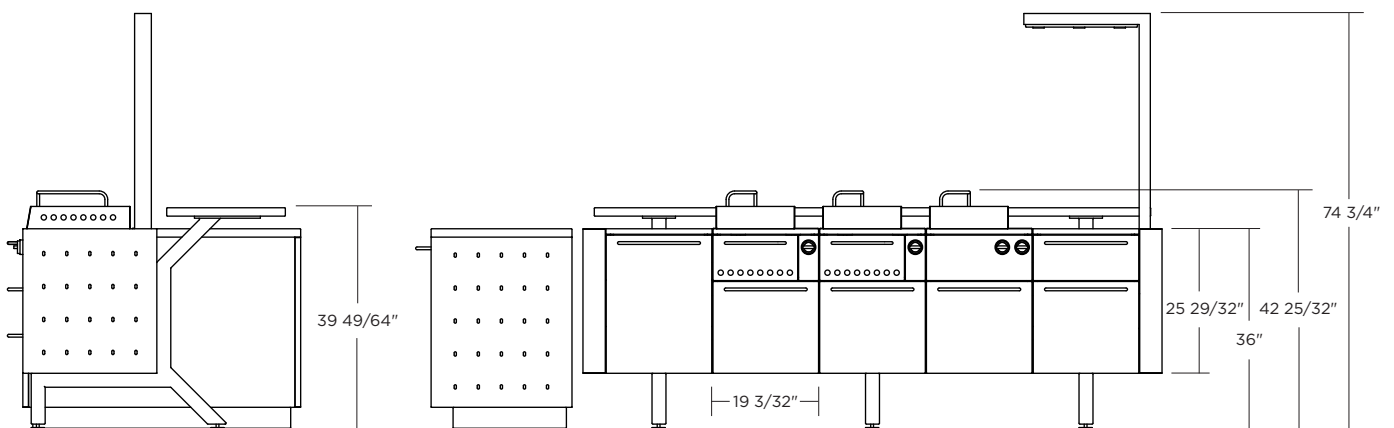

Side

Front

